

VOLANT COOL AIR INTAKES  
 PART NO.: 16257  
 INSTALLATION INSTRUCTIONS  
 WWW.VOLANT.COM  
 TECH SUPPORT: (909) 481-3888

16257 PARTS LIST					
1	VOLANT FILTER BOX	2	#064 CLAMPS	1	6 MM NUT
1	VOLANT FILTER BOX ADAPTER	1	3 1/2" X 2 3/4" SLEEVE	1	VOLANT BRACKET (SHORT)
1	VOLANT RAM AIR SCOOP	1	3" X 3" SLEEVE	1	VOLANT BRACKET (LONG)
1	VOLANT DUCT	1	4" X 3" HUMP HOSE	1	1/2" RUBBER GROMMET
1	RAM FILTER W/CLAMP	2	1/4"-20 BOLTS	1	1/2" X 14" BREATHER HOSE
2	#048 CLAMPS	3	1/4" WASHERS	1	1/2" X 11" VINYL TRIM
2	#056 CLAMPS	1	1/4" LOCK WASHERS		

TOP VIEW

FRONT VIEW

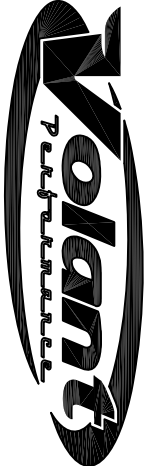
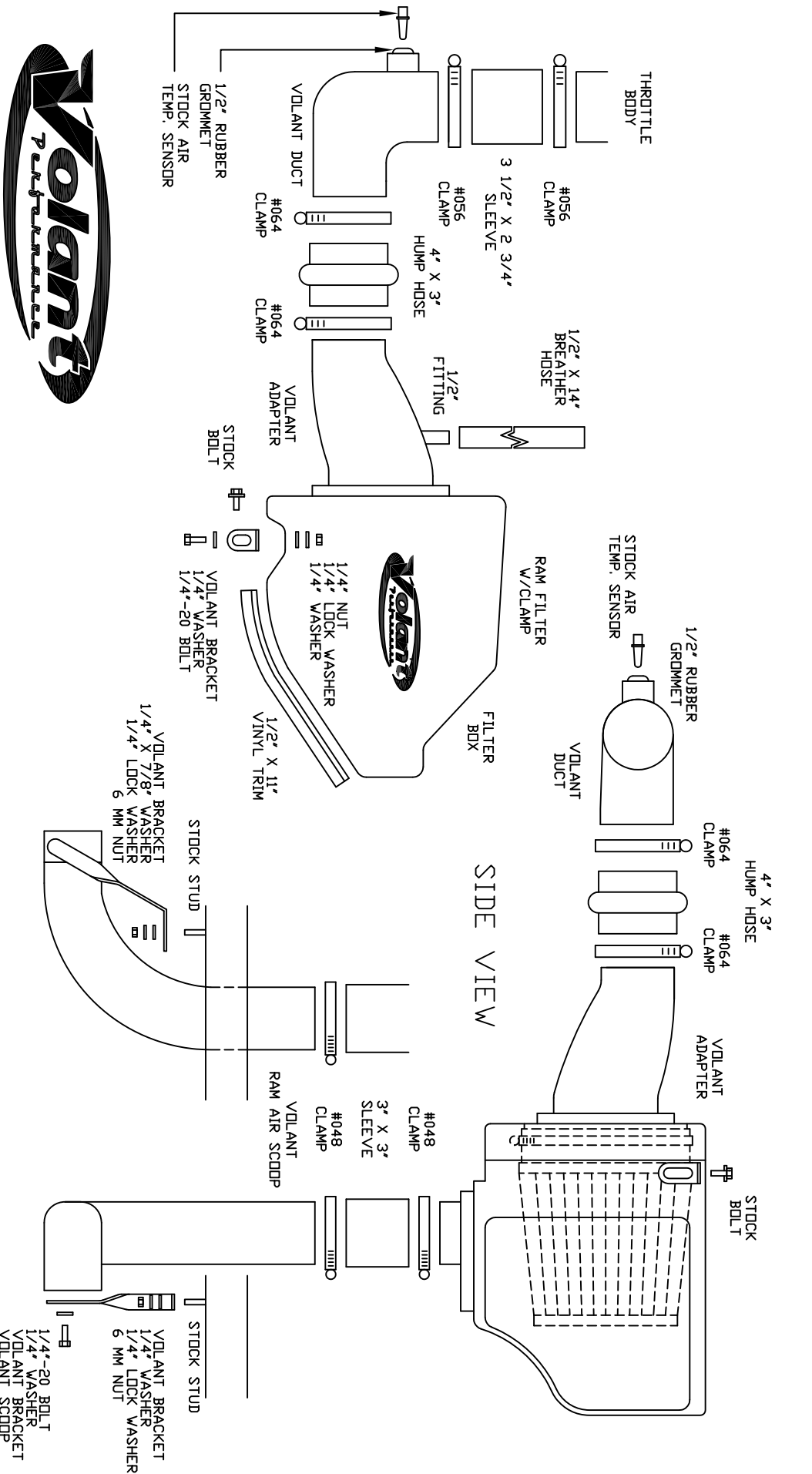



## Installation Instructions

16257 / 162576

Dodge Challenger 11-13 5.7L



Disconnect the negative battery cable and remove the engine cover by lifting up and pulling out.



Place the filter in the volant box and tighten the clamp through the access hole in the air box.



Press the ATS sensor into the rubber grommet.



Disconnect the wiring harness from the AIT sensor than twist the sensor and pull straight out.



Mount the volant air box in the factory location using the supplied hardware and the stock bolt.



Press the duct inside of the hump hose and sleeve and tighten the clamps.



Loosen the clamps holding the duct to the throttle body and air box. Remove the factory breather hose.



Install the supplied trim sponge on the core support.



Attach the supplied breather hose and ATS harness. Reinstall the factory engine cover.

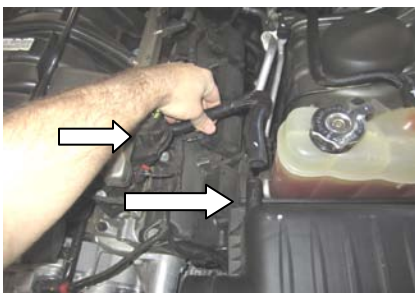

Remove the factory breather hose from the crankcase and air box. Remove the air box mounting bolt and air box.



Attach the hump hose to the filter adapter and tighten the clamp.



Remove the skid plate to access the bottom of the air box. This consists of several 10mm and 7mm bolts as well as push pins

## Installation Instructions Continued



Remove the panel in the photo it is located behind the front bumper in front of the fog light.



Attach the bracket to the factory stud using the provided hardware.



Clamp the sleeve to the bottom of the air box.



Press the harness into the predrilled hole on the scoop. Reinstall the skid plate. Reconnect the battery cable.



Attach the scoop bracket to the scoop and press the scoop into the sleeve and tighten the clamp.



Not street legal in CA and other states adopting CA emission standards, Volant recommends saving your factory system