

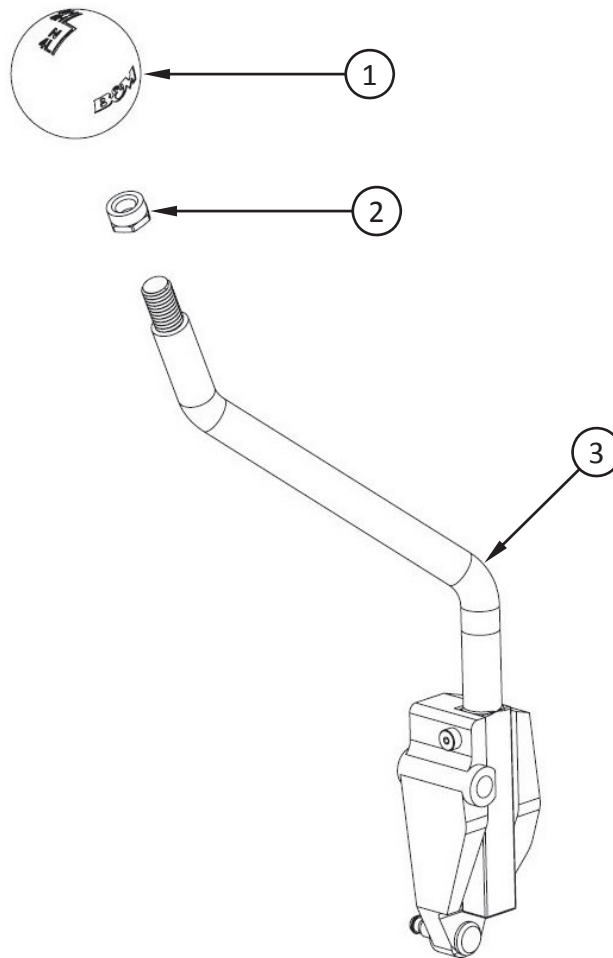

Installation Instructions  
**81152**  
**TRANSFER CASE SHIFT HANDLE**  
**2007-18 JEEP JK WRANGLER**



ITEM NO.	PART NO.	DESCRIPTION	QTY.
1	4101359	SHIFT KNOB, JEEP WRANGLER JK, MOLDED	1
2	1794720	JAM NUT, 3/8-16UNC, SHIFT KNOB, BLACK	1
3	N/A (SHIPS ASSEMBLED)	SHIFT LEVER, TRANSFER CASE, 07-18 JEEP JK	1
N/A	4101372	• STICK, JEEP WRANGLER EXTENDED T-CASE	1
	4101373	• CARRIER HOUSING, JEEP WRANGLER EXTENDED T-CASE	1
	4101374	• PIN, JEEP WRANGLER EXTENDED T-CASE	1
	3401592	• SPRING, COMPRESSION .258" I.D. X 1" LONG	1
	3401593	• SCREW, SHOULDER 8-32 X 3/16" X 1" L, 18-8 S.S.	1

## REVIEW THE INSTRUCTIONS AND VERIFY THE KIT CONTENTS

1. Take a moment to read and understand these instructions before installing your B&M transfer case shift handle.



2. Use the parts drawing and list (front page) to verify your kit's contents. In the unlikely event that any parts are missing, please contact B&M Technical Support for replacements.

**NOTE: Do not attempt to disassemble the shift lever, as it has been assembled by B&M to precise tolerances. ATTEMPTED DISASSEMBLY OF THE SHIFT LEVER VOIDS THE WARRANTY.**

## REMOVE THE STOCK SHIFT HANDLE

**NOTE: Retain all factory parts.**

3. To prevent the vehicle from rolling when the shifters are manipulated, set the parking brake. Pull the brake handle all the way up, to provide the necessary clearance for the removal and installation of the center console cover.



4. Grasp the gearshift knob firmly with both hands and pull it straight off the end of the shift lever.



5. Grasp the transfer case shift knob firmly with both hands and pull it straight off the end of the lever.



6. At the center console cup holders, lift the console cover up to separate it from the center console.



7. Carefully remove the console cover by lifting the leather boot over the gearshift lever, while rotating the cover clear of the center console storage lid and the emergency brake handle.



8. On the underside of the console cover, release the 2 tabs at the rear of the leather boot, then remove the boot from the cover.



11. The end of the transfer case shifter cable is held on the pin at the bottom of the shift lever by friction. Carefully pry the cable end off the pin.



9. Use a screwdriver to release the two tabs at the rear of the dust cover, and slightly lift the rear of the cover. Then release the two front tabs by hand, and remove the dust cover from the shifter base.



12. Remove the pivot pin and the stock shift lever from the shifter base.



10. Remove the push-on retainer from the tip of the shift lever pivot pin.

## INSTALL YOUR B&M SHIFT HANDLE



13. Place the B&M shift lever (3) in the shifter base, then install the pivot pin.



14. Seat the pivot pin by tapping gently.



15. Push the retainer onto the tip of the pivot pin.



16. Push the end of the transfer case shifter cable back onto its pin until you hear or feel it "click" in place, then verify the security of the connection. Verify smooth movement of the shift lever throughout its entire range.



17. Slip the dust cover over the shift lever, then press it onto the shifter base. Verify the security of all 4 locking tabs. Move the shift lever to the "4 High" position.



18. Open the center console storage lid, and carefully reinstall the center console cover.



19. Slip the leather boot over the gearshift lever. Slip the 2 front hooks under the edge of the console cover, then press the 2 rear locking tabs into place.



20. Press the gearshift knob onto the gearshift lever.



23. Tighten the jam nut against the knob.



21. Install the jam nut (2) on the shift lever, with the wrench flats down. Run the nut all the way down to the shoulder.



**Congratulations, the installation of your B&M Transfer Case Shift Handle is now complete!**



22. Install the shift knob (1) on the shift lever. Thread it on to the lever as far as possible with the shift pattern correctly oriented.

---

**IMPORTANT: RETAIN THESE INSTRUCTIONS FOR FUTURE REFERENCE**

