

GROSS LOAD CAPACITY WHEN USED AS A WEIGHT CARRYING HITCH: 1,000 LBS. TRAILER WEIGHT & 100 LBS. TONGUE WEIGHT.

**\*\*\*DO NOT EXCEED VEHICLE MANUFACTURER'S RECOMMENDED TOWING CAPACITY.\*\*\***

**WARNING: ALL NON-TRAILER LOADS APPLIED TO THIS PRODUCT MUST BE SUPPORTED BY AUXILIARY STABILIZING STRAPS.**

**\*\* FAILURE TO PROPERLY SUPPORT NON-TRAILER LOADS WILL VOID PRODUCT WARRANTY\*\***

HAVING INSTALLATION QUESTIONS? CALL TECHNICAL SUPPORT AT 877-287-8634

Parts List			
ITEM	QTY	PART NUMBER	DESCRIPTION
1	2	10-10314	BOLT,CAR,7/16-14 UNC,1-3/4,GRD8,YZ
2	2	CM-SP11	.250 x 1.00 x 2.50" SQUARE HOLE SPACER
3	2	7_16 FISHWIRE	7/16" FISHWIRE
4	2	20-00103	NUT,SER-FLANGE,7/16-14 UNC,GRD8,YZ
5	4	20-00062	NUT, SER-FLANGE,1/2-13 UNC,GRD8,YZ
6	2	CM-1210-UBS	1/2-13 x 3.500 x 3.500 C-C U-BOLT

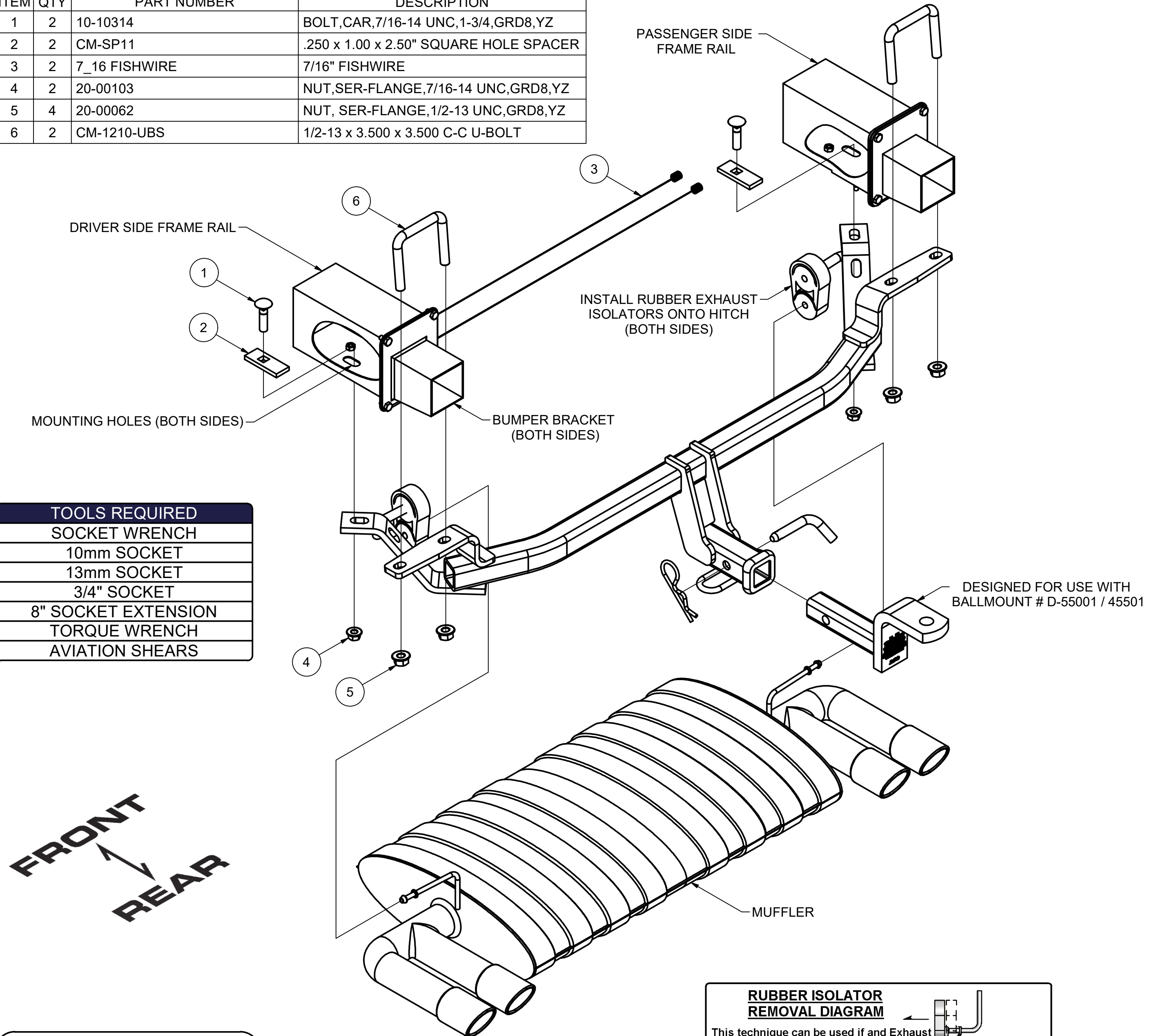

TOOLS REQUIRED
SOCKET WRENCH
10mm SOCKET
13mm SOCKET
3/4" SOCKET
8" SOCKET EXTENSION
TORQUE WRENCH
AVIATION SHEARS



HITCH WEIGHT: 23 LBS.  
 INSTALL TIME  
 PROFESSIONAL: 45 MINUTES  
 NOVICE (DIY): 90 MINUTES  
 INSTALL NOTES:  
 - NO DRILLING REQUIRED  
 - LOWER EXHAUST  
 - REMOVE EXHAUST HANGERS  
 - HEAT SHIELD TRIMMING OPTIONAL  
 - FISHWIRE HARDWARE

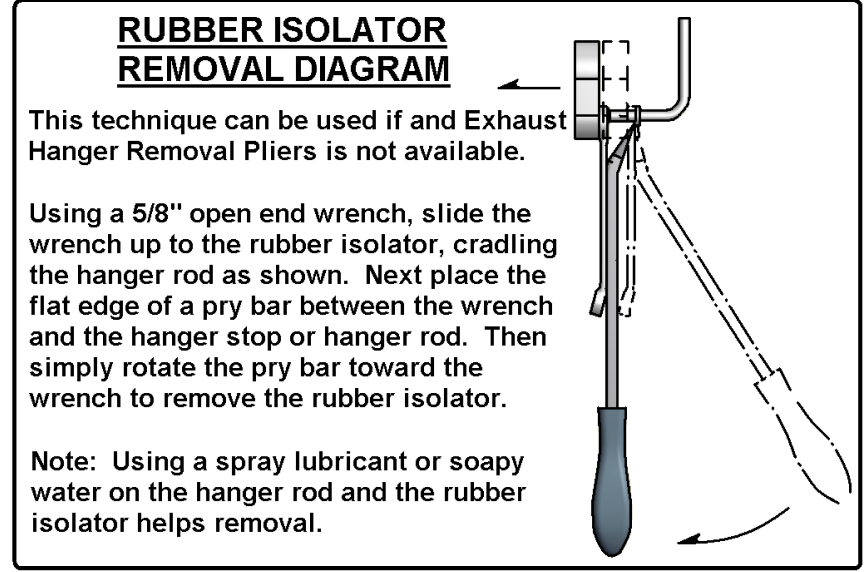
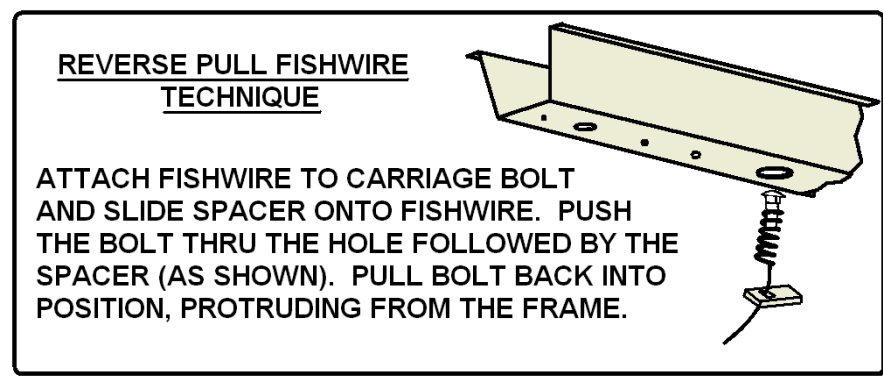

**PERIODICALLY CHECK THIS RECEIVER HITCH TO ENSURE THAT ALL FASTENERS ARE TIGHT AND THAT ALL STRUCTURAL COMPONENTS ARE SOUND.**

Curt Manufacturing Inc., warrants this product to be free of defects in material and/or workmanship at the time of retail purchase by the original purchaser. If the product is found to be defective, Curt Manufacturing Inc., may repair or replace the product, at their option, when the product is returned, prepaid, with proof of purchase. Alteration to, misuse of, or improper installation of this product voids the warranty. Curt Manufacturing Inc.'s liability is limited to repair or replacement of products found to be defective, and specifically excludes liability for incidental or consequential loss or damage.

GROSS LOAD CAPACITY WHEN USED AS A WEIGHT CARRYING HITCH: 1,000 LBS. TRAILER WEIGHT & 100 LBS. TONGUE WEIGHT.

**\*\*\*DO NOT EXCEED VEHICLE MANUFACTURER'S RECOMMENDED TOWING CAPACITY.\*\*\***

WARNING: ALL NON-TRAILER LOADS APPLIED TO THIS PRODUCT MUST BE SUPPORTED BY AUXILIARY STABILIZING STRAPS.

**\*\* FAILURE TO PROPERLY SUPPORT NON-TRAILER LOADS WILL VOID PRODUCT WARRANTY\*\***

HAVING INSTALLATION QUESTIONS? CALL TECHNICAL SUPPORT AT 877-287-8634

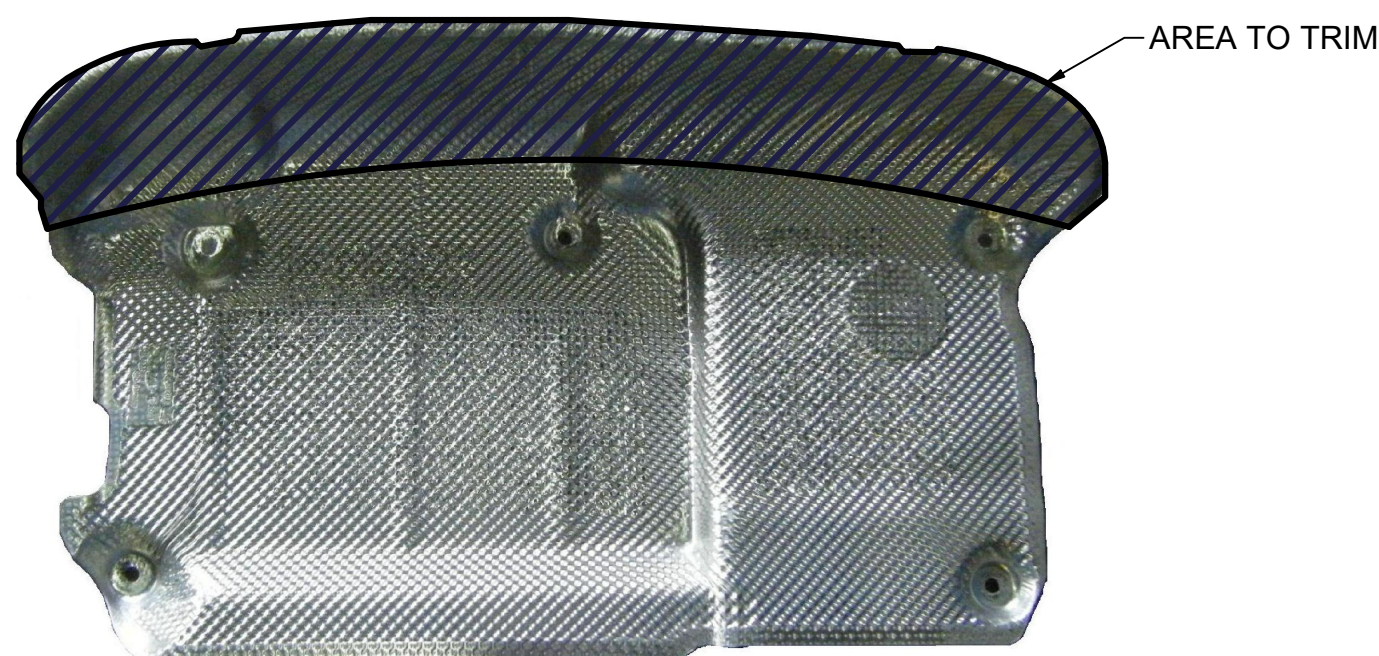

HEAT SHIELD TRIMMING DIAGRAM

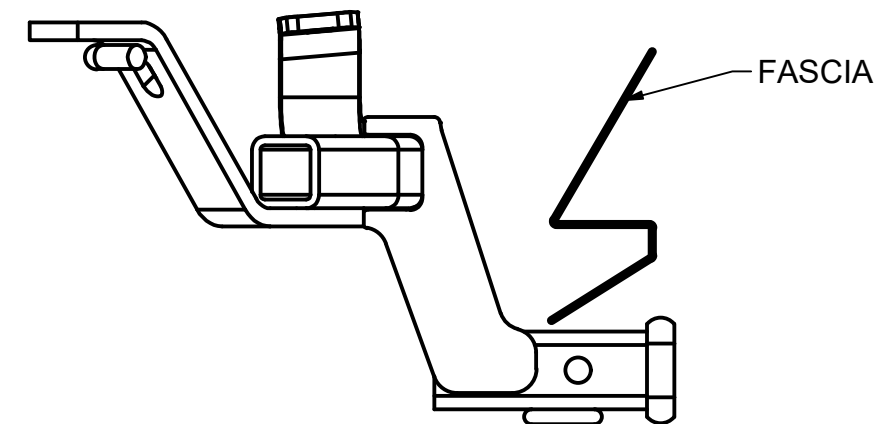

INSTALLED HITCH POSITION

### **INSTALLATION STEPS**

1. Remove one (1) existing bolt and one (1) existing nut from the exhaust hanger on the driver and passenger side of vehicle. Return hardware to vehicle owner.
2. Remove one (1) rubber isolator in front of vehicle muffler to allow exhaust to hang lower for hitch installation. (See Rubber Isolator Removal Diagram.)
3. Remove exhaust hangers and rubber isolators from Step 1 off of muffler.
4. Separate rubber isolators from exhaust hangers from Step 3. Return exhaust hangers to vehicle owner.
5. Install rubber isolators from Step 4 onto threaded exhaust hangers on hitch, as shown.
6. If desired, remove heat shield by removing five (5) screws. Retain screws for heat shield reinstallation. Trim heat shield according to Heat Shield Trimming Diagram. (Note: Trimming of heat shield is not necessary for hitch installation. The shield may be bent away from hitch during installation if trimming is undesired.)
7. Reinstall heat shield with screws from Step 6 if trimming was performed. If the heat shield was not removed, skip to Step 8.
8. Reverse pull fishwire 7/16" carriage bolts and CM-SP11 spacers through mounting holes in frame rails. Leave fishwires attached to hardware for ease of installation (See Reverse Pull Fishwire Technique.)
9. Install 1/2" U-Bolts over bumper bracket on driver and passenger side of vehicle, as shown. (Note: Install U-bolts from inside of frame rails.)
10. Raise hitch over exhaust and insert 7/16" carriage bolts and 1/2" U-bolts through corresponding holes in hitch, as shown.
11. Secure U-bolts with 1/2-13 hex flange nuts.
12. Remove fishwires and secure carriage bolts with 7/16-14 hex flange nuts.
13. Torque 1/2" hardware to 110 lb-ft and 7/16" hardware to 59 lb-ft.
14. Raise exhaust and insert muffler exhaust hangers through rubber isolators on hitch.
15. Reattach rubber exhaust isolator in front of muffler.

**PERIODICALLY CHECK THIS RECEIVER HITCH TO ENSURE THAT ALL FASTENERS ARE TIGHT AND THAT ALL STRUCTURAL COMPONENTS ARE SOUND.**