

YEARS: 2011

MAKE: FORD

MODEL: EXPLORER (EXCLUDES 2.0L ECOBOOST)

STYLE: SUV

WARNING: NEVER EXCEED YOUR VEHICLE MANUFACTURER'S RECOMMENDED TOWING CAPACITY

WEIGHT CARRYING:
 TRAILER WEIGHT: 3,500 LBS.
 TONGUE WEIGHT: 350 LBS.

GROSS LOAD CAPACITY WHEN USED AS A STRAIGHT LINE PULL:
 9,000 LBS MAX.

INSTALLATION TIME: 30 MIN.

THE INSTALL TIME LISTED IS FOR PROFESSIONAL INSTALLERS. IF YOU ARE HESITANT TO UNDERTAKE THIS TASK ON YOUR OWN, CONTACT AN AUTHORIZED CURT INSTALLER FOR ADDITIONAL ASSISTANCE.

INSTALLATION REQUIRES:

RATCHET	3/4" SOCKET	POWER DRILL
DRILL BIT 9/16"	TORQUE WRENCH	TAPE MEASURE
MARKER	UTILITY KNIFE	SAFETY GLASSES
MASKING TAPE	ROTARY TOOL	

INSTALLATION TIPS:

- BEFORE YOU BEGIN INSTALLATION, READ ALL INSTRUCTIONS THOROUGHLY.
- TO EASE INSTALLATION, 2 PEOPLE MAY BE REQUIRED.
- USING PROPER TOOLS WILL GREATLY IMPROVE THE QUALITY OF THE INSTALL AND REDUCE THE TIME REQUIRED.
- NEED HELP OR HAVE SOME QUESTIONS? CALL TECHNICAL SUPPORT AT 800.798.0813

LEVEL OF DIFFICULTY: MODERATE

EASY	MODERATE	CHALLENGING
	DRILLING REQUIRED	
	FASCIA TRIMMING REQUIRED	
	FISHWIRE HARDWARE	

VEHICLE PHOTO:



REPRESENTATIVE PHOTO

HITCH ILLUSTRATION:

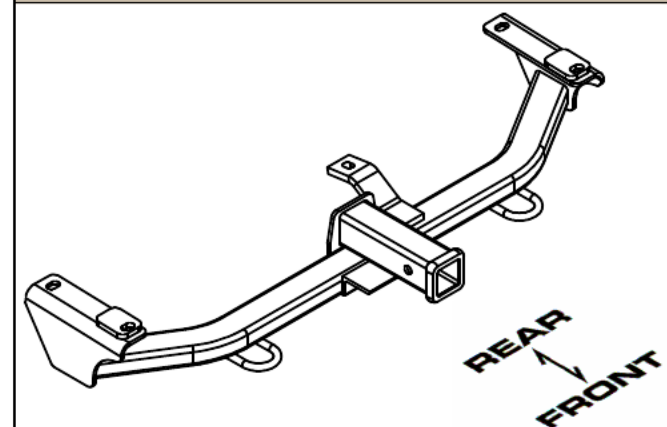

MAKE SURE YOUR HITCH MATCHES

PERIODICALLY CHECK THIS RECEIVER HITCH TO ENSURE ALL FASTENERS ARE TIGHT AND ALL STRUCTURAL COMPONENTS ARE SOUND

CURT Manufacturing LLC. warrants this product to be free of defects in material and/or workmanship at the time of retail purchase by the original purchaser. If the product is found to be defective, Curt Manufacturing LLC. may repair or replace the product at their option, when the product is returned, prepaid, with proof of purchase. Alteration to, misuse of, or improper installation of this product voids the warranty. Curt Manufacturing LLC.'s liability is limited to repair or replacement of products found to be defective, and specifically excludes liability for incidental or consequential loss or damage.

INSTALLATION WALKTHROUGH:

Parts List			
ITEM	QTY	PART NUMBER	DESCRIPTION
1	2	1/2-13 x 1 1/2	CARRIAGE BOLT
2	2	1/2-13 x 3 1/2	CARRIAGE BOLT
3	1	1_2 - 13 x 4 1_2 HEX	HEX BOLT
4	4	CM-SP6	.250 x 1.00 x 3.00" SQUARE HOLE SPACER
5	1	FW12	FW, 12, ZP
6	5	HFN 1213	HEX FLANGE NUT
7	2	1_2 FISHWIRE	1/2" FISHWIRE

FISHWIRE TECHNIQUE

INSERT COILED END OF FISHWIRE TOOL THROUGH HITCH MOUNTING HOLE IN VEHICLE FRAME RAIL AND OUT THE ACCESS HOLE. PASS COILED END OF FISHWIRE THROUGH SPACER AND THREAD BOLT INTO COIL. KINK WIRE TO KEEP SPACER SEPARATE FROM BOLT AS SHOWN. PULL FISHWIRE, SPACER, AND BOLT THROUGH FRAME AND OUT MOUNTING HOLE. USE FISHWIRE TO GUIDE HITCH DURING MOUNTING AND PREVENT LOSS OF BOLT / SPACER INSIDE FRAME RAIL.

NOTE: SOME VEHICLES MAY FISHWIRE THROUGH END OF FRAME

TRIM DIAGRAM

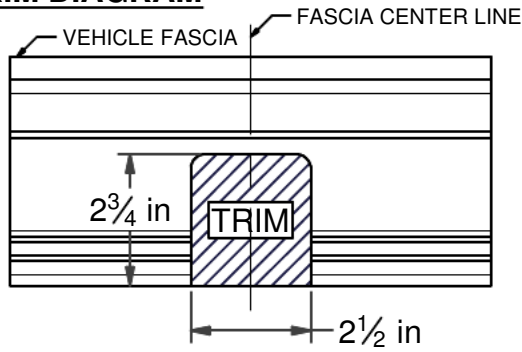

NOTE: Trim dimensions are approximate. Check fit prior to completing trim.

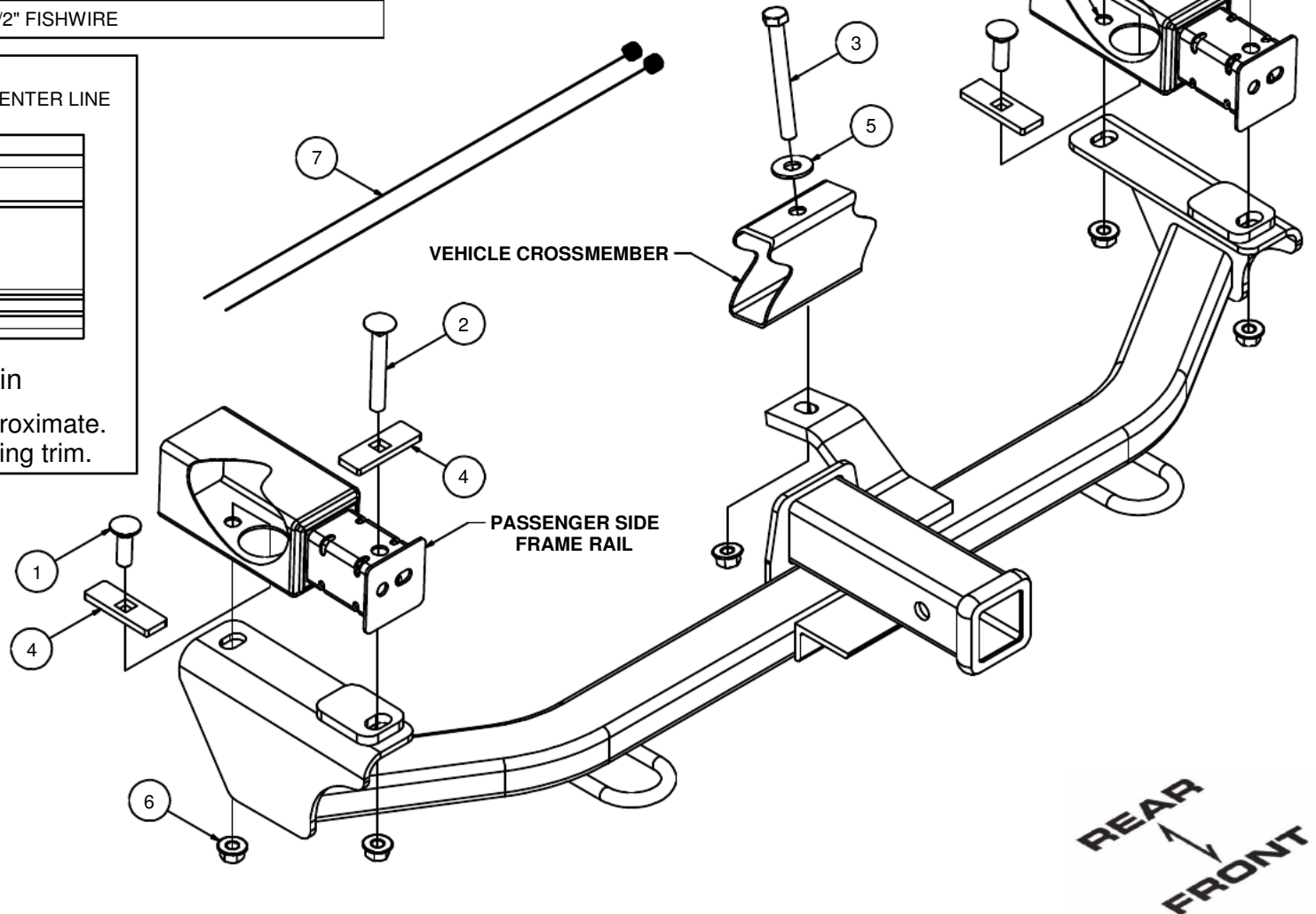

INSTALLATION WALKTHROUGH:

1. Mark fascia and trim. See TRIM DIAGRAM on page 2.
(**Note:** Check fit prior to completing trim.)

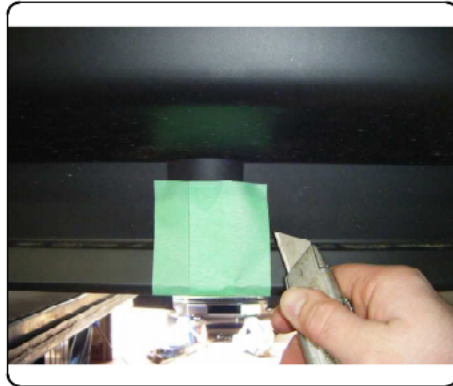

2. Place 3 1/2" carriage bolt with CM-SP6 spacer through the top of each frame rail.



3. Insert 4" hex bolt with 1/2" washer through the top of vehicle cross member. (**Note:** Hoses above the cross member and the strap which holds the hoses may need to be moved slightly to get the hardware into position.)



4. Raise hitch into position and mark drill hole locations.

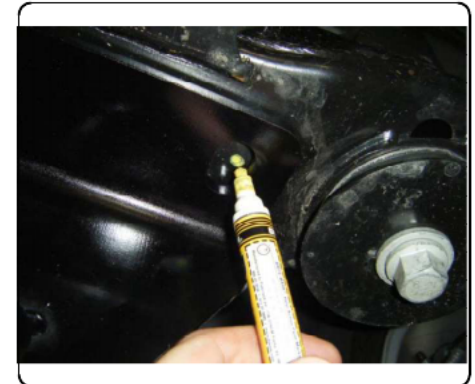

INSTALLATION WALKTHROUGH:

5. Lower hitch and drill holes.



6. Fishwire 1/2" carriage bolts and CM-SP6 spacers into position through access holes into drilled holes. See FISHWIRE DIAGRAM on page 2.



7. Raise hitch into position and secure to vehicle with (5) 1/2" flange nuts.



8. Torque all 1/2" hardware to 110 ft-lbs.
Install is complete.



31052 FORD EXPLORER (EXCLUDES 2.0L ECOBOOST)

12/10/2012

GROSS LOAD CAPACITY WHEN USED AS A WEIGHT CARRYING HITCH: 3,500 LBS. TRAILER WEIGHT & 350 LBS. TONGUE WEIGHT.

GROSS LOAD CAPACITY WHEN USED AS A STRAIGHT LINE PULL: 9,000 LBS. MAX. LINE PULL.

*** DO NOT EXCEED VEHICLE MANUFACTURER'S RECOMMENDED TOWING CAPACITY. ***

HAVING INSTALLATION QUESTIONS? CALL TECHNICAL SUPPORT AT 1-877-287-8634

		Parts List	
ITEM	QTY	PART NUMBER	DESCRIPTION
1	2	1/2-13 x 1 1/2	CARRIAGE BOLT
2	2	1/2-13 x 3 1/2	CARRIAGE BOLT
3	1	1_2 - 13 x 4 1_2 HEX	HEX BOLT
4	4	CM-SP6	.250 x 1.00 x 3.00" SQUARE HOLE SPACER
5	1	FW12	FW, 12, ZP
6	5	HFN 1213	HEX FLANGE NUT
7	2	1_2 FISHWIRE	1/2" FISHWIRE

TOOLS REQUIRED
RATCHET
3/4" SOCKET
DRILL
9/16" DILL BIT
TORQUE WRENCH
TAPE MEASURE
MARKER
UTILITY KNIFE

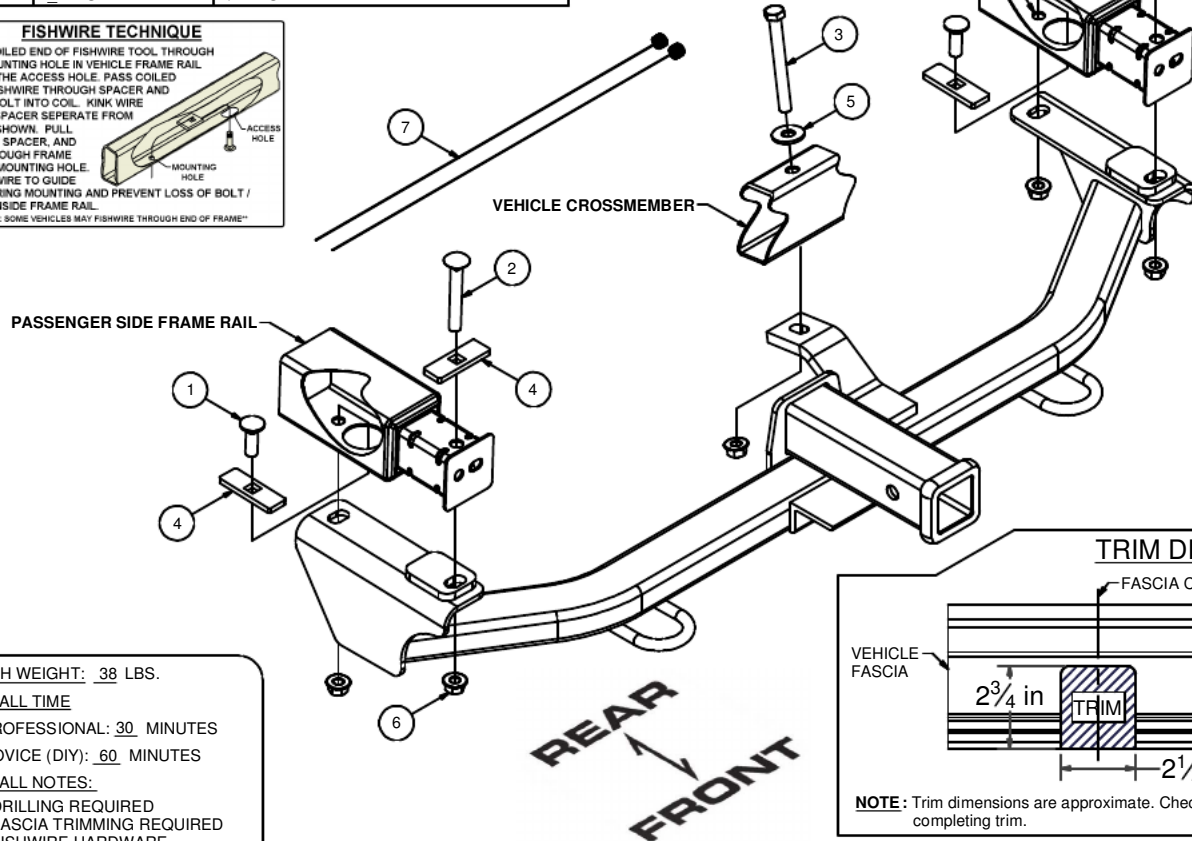
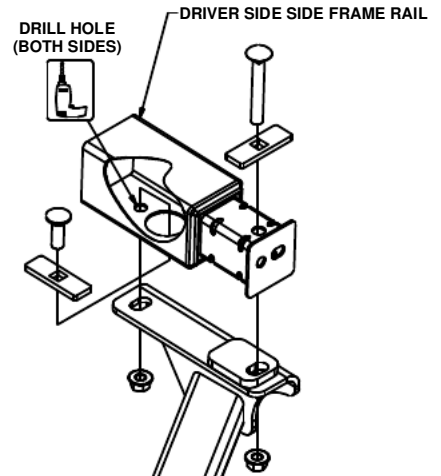
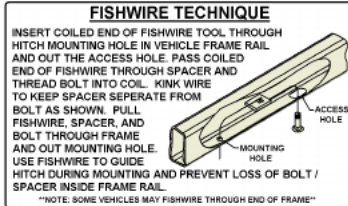

HITCH WEIGHT: .38 LBS.

INSTALL TIME

PROFESSIONAL: 30 MINUTES

NOVICE (DIY): 60 MINUTES

INSTALL NOTES:

- DRILLING REQUIRED
- FASCIA TRIMMING REQUIRED
- FISHWIRE HARDWARE

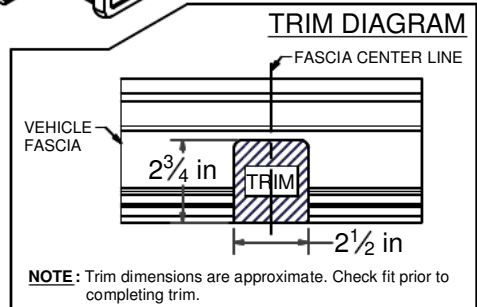

INSTALLATION STEPS

1. Mark fascia and trim. See TRIM DIAGRAM above. (**Note:** Check fit prior to completing trim.)
2. Place 3 1/2" carriage bolt with CM-SP6 spacer through the top of each frame rail, as shown above.
3. Insert 4" hex bolt with 1/2" washer through the top of vehicle cross member. (**Note:** Hoses above the cross member and the strap which holds the hoses may need to be moved slightly to get the hardware into position.)
4. Raise hitch into position and mark drill hole locations.
5. Lower hitch and drill holes.
6. Fishwire 1/2" carriage bolts and CM-SP6 spacers into position though access holes into drilled holes. See FISHWIRE DIAGRAM above.
7. Raise hitch into position and secure to vehicle with (5) 1/2" flange nuts.
8. Torque all 1/2" hardware to 110 ft-lbs.

PERIODICALLY CHECK THIS RECEIVER HITCH TO ENSURE THAT ALL FASTENERS ARE TIGHT AND THAT ALL STRUCTURAL COMPONENTS ARE SOUND.

Curt Manufacturing Inc., warrants this product to be free of defects in material and/or workmanship at the time of retail purchase by the original purchaser. If the product is found to be defective, Curt Manufacturing Inc., may repair or replace the product, at their option, when the product is returned, prepaid, with proof of purchase. Alteration to, misuse of, or improper installation of this product voids the warranty. Curt Manufacturing Inc.'s liability is limited to repair or replacement of products found to be defective, and specifically excludes liability for incidental or consequential loss or damage.

*****DO NOT EXCEED VEHICLE MANUFACTURER'S RECOMMENDED TOWING CAPACITY ***.**

FRONT MOUNTED ACCESSORIES

1) Do not exceed front axle Gross Weight Rating (GAWR). Consult owners manual or specification plate located on driver's door frame. Measure gross front axle weight by placing front wheels of loaded vehicle on a scale.

WARNING: Exceeding GAWR may overload the front axle and/or suspension. This could result in **accident, property damage and personal injury.**

- 2) Reposition front mounted license plate if obstructed.
- 3) Do not obstruct vehicle lights.
- 4) Allow free air flow into grille opening.
- 5) Rear wheel traction may be reduced. This could effect handling. Reduce speed and drive with caution.
- 6) Accessories extend front of vehicle. This may reduce approach angle. Use caution when parking and maneuvering.
- 7) Do not obstruct driver view.

VEHICLE RECOVERY AND WINCHING TIPS

1) Use OEM tow hooks, recovery eyes or a clevis mount for attachment of a tow strap or winch cable.

WARNING: NEVER use a ball and/or ball mount as an anchor point for tow strap or winch cable. Severe personal injury or death could result.

- 2) Observe winch manufacturer's recommendations, cautions and warnings.
- 3) Attach return cable to tow hook or recovery eye when using a snatch block (See figure 1).

CAUTION: Do not attach return cable to winch mount. This may overload winch mount and/or front mounted receiver.

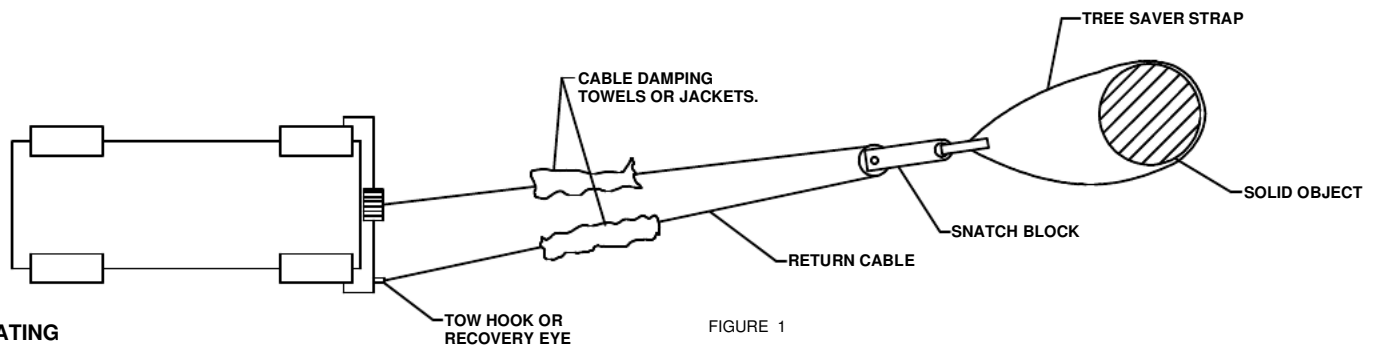

RATING

For **Maximum** line pull rating, winch cable must not exceed:

- 15 degree angle up or down from horizontal (See Figure 2).
- 45 degree angle left or right from straight ahead (See Figure 3).

CAUTION: Exceeding the maximum line pull rating may over load winch, winch mount, and/or front mounted receiver.

