



13342 INSTALLATION INSTRUCTIONS



Safety glasses should be worn at all times while installing this product.

YEARS: SEE PAGE 2

MAKE: MERCEDES-BENZ

MODEL: ML350 (EXCEPT BLUE TEC), ML500, ML320 CDI, ML550

STYLE: SUV

(WILL NOT FIT VEHICLES EQUIPPED WITH AIR SUSPENSION)

WARNING: NEVER EXCEED YOUR VEHICLE MANUFACTURER'S RECOMMENDED TOWING CAPACITY

WEIGHT CARRYING:
TRAILER WEIGHT: 3,500 LBS.
TONGUE WEIGHT: 350 LBS.

WEIGHT DISTRIBUTION:
TRAILER WEIGHT: 4,000 LBS.
TONGUE WEIGHT: 400 LBS.

INSTALLATION TIME: 60 MIN.

THE INSTALL TIME LISTED IS FOR PROFESSIONAL INSTALLERS. IF YOU ARE HESITANT TO UNDERTAKE THIS TASK ON YOUR OWN, CONTACT AN AUTHORIZED CURT INSTALLER FOR ADDITIONAL ASSISTANCE.



INSTALLATION REQUIRES:

 RATCHET	 TORQUE WRENCH	 9" SOCKET EXTENSION
 10mm 13mm 16mm 3/4" SOCKET	 25 TORXBIT SOCKET	 POWER DRILL
 DRILL BIT 17/32"	 CENTER PUNCH	 AVIATION SHEARS

INSTALLATION TIPS:

1. BEFORE YOU BEGIN INSTALLATION, READ ALL INSTRUCTIONS THOROUGHLY.
2. TO EASE INSTALLATION, 2 PEOPLE MAY BE REQUIRED.
3. USING PROPER TOOLS WILL GREATLY IMPROVE THE QUALITY OF THE INSTALL AND REDUCE THE TIME REQUIRED.
4. NEED HELP OR HAVE SOME QUESTIONS? CALL TECHNICAL SUPPORT AT 800.798.0813

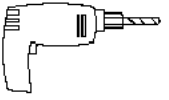
LEVEL OF DIFFICULTY: MODERATE

EASY	MODERATE	HARD
	- DRILLING REQUIRED	
	- MAY REQUIRE FASCIA TRIMMING	

VEHICLE PHOTO:



REPRESENTATIVE PHOTO

HITCH ILLUSTRATION:

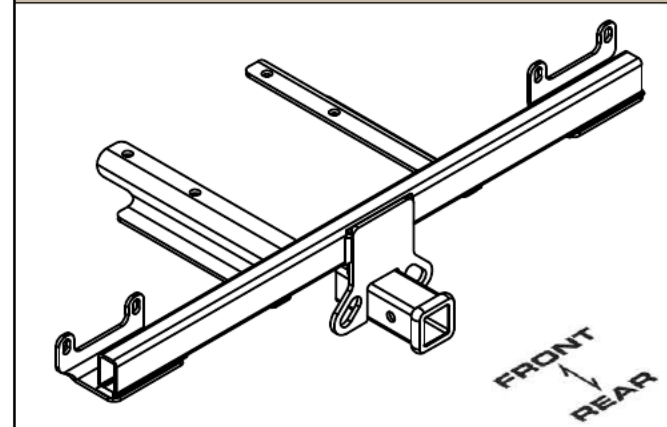

MAKE SURE YOUR HITCH MATCHES

PERIODICALLY CHECK THIS RECEIVER HITCH TO ENSURE ALL FASTENERS ARE TIGHT AND ALL STRUCTURAL COMPONENTS ARE SOUND

CURT Manufacturing Inc. warrants this product to be free of defects in material and/or workmanship at the time of retail purchase by the original purchaser. If the product is found to be defective, Curt Manufacturing Inc. may repair or replace the product at their option, when the product is returned, prepaid, with proof of purchase. Alteration to, misuse of, or improper installation of this product voids the warranty. Curt Manufacturing Inc.'s liability is limited to repair or replacement of products found to be defective, and specifically excludes liability for incidental or consequential loss or damage.

INSTALLATION WALKTHROUGH:

2006-2010 MERCEDES-BENZ ML350 (EXCEPT BLUE TEC)
2006-2007 MERCEDES-BENZ ML500
2007-2008 MERCEDES-BENZ ML320 CDI
2008-2009 MERCEDES-BENZ ML550

WILL NOT FIT VEHICLES EQUIPPED WITH AIR SUSPENSION

Parts List			
ITEM	QTY	PART NUMBER	DESCRIPTION
1	2	CM-SP4	.250 x 1.50 x 3.00" SQUARE HOLE SPACER
2	2	CM-SP6	.250 x 1.00 x 3.00" SQUARE HOLE SPACER
3	4	1/2-13 x 1 3/4	CARRIAGE BOLT
4	4	HFN 1213	HEX FLANGE NUT

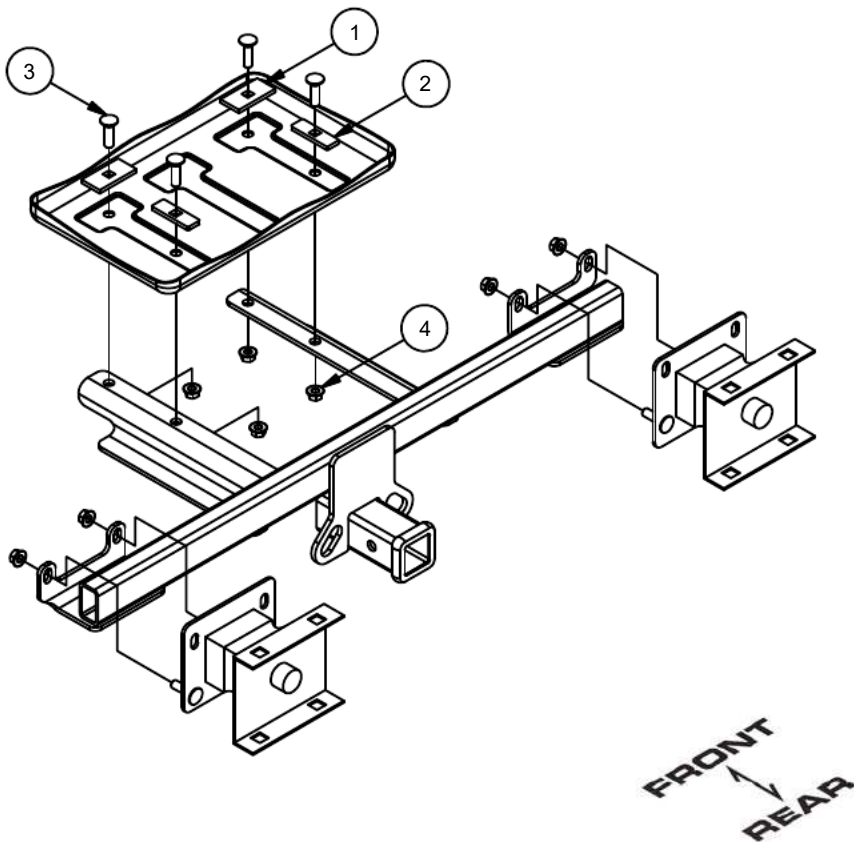

NOTE:

- Will not fit vehicles equipped with air suspension.
- If installing on a ML350 2010 or newer; Trim the center web of the lower rear fascia. Trim off the center plastic fascia tab and the metal tab it is attached to.

** See photos 1, 2, and 3 on page 2 of 2 **

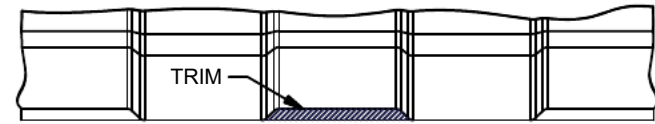

FASCIA REAR VIEW

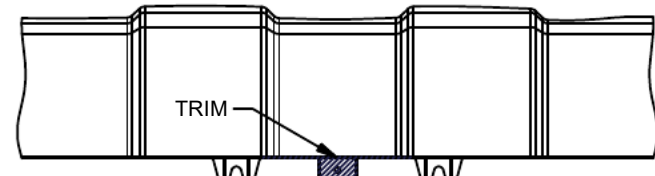

FASCIA BOTTOM VIEW



Note: These install photos are of a 2008 ML320 CDI.

Your install may vary slightly.

1. Remove (4) fascia screws, retain (2) screws for later use. Remove the fastener securing the center fascia bracket and return bracket and bracket fasteners to owner.



INSTALLATION WALKTHROUGH:

2. Remove (4) nuts securing the trunk pan cover and remove cover. **Note:** Trunk pan cover may be trimmed and reinstalled if desired. (See Step (8) for trim details.)



3. If needed bend back heat shields and remove (4) M10 nuts from the bumper bracket weld studs.



4. Raise hitch into position and secure to bumper bracket weld studs using (4) M10 nuts removed in Step (3). Re-install (2) fascia screws removed in Step (1). **Note:** Gently flex fascia and fascia brackets to slide hitch into position. You may temporarily remove (2) fascia brackets if needed.



5. Open hatch, remove spare tire, foam tire locator, and pull carpet back. **Note:** When pulling carpet back push the carpet tab below the plastic trim and carefully fold it towards the front of the vehicle.



INSTALLATION WALKTHROUGH:

6. Remove (2) rubber hole plugs and return to owner. Using hitch as template, drill the (2) forward-most holes in the trunk pan.

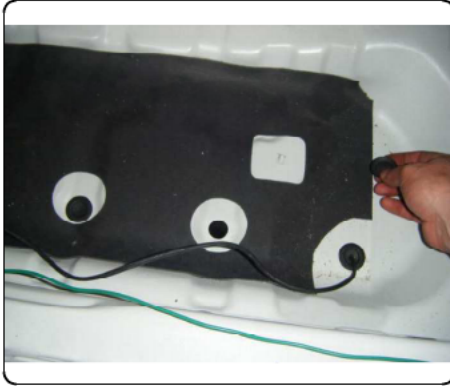

7. Install 1/2-13 x 1 3/4" carriage bolts and SP6 spacers in the rear-most holes of trunk pan. Install 1/2-13 x 1 3/4" carriage bolts and SP4 spacers in the forward-most drilled holes of trunk pan. Secure bolts using 1/2-13 flange nuts. Use silicone caulk or equivalent to seal holes in trunk. Re-install carpet, foam spare tire locator, and spare tire.



8. Torque all M10 fasteners to 48 ft-lbs. Torque all 1/2" fasteners to 110 ft-lbs. If desired you may trim the trunk pan cover and re-attach using nuts removed in Step (2). **Note:** Dimensions are approximate, confirm fit prior to trimming.

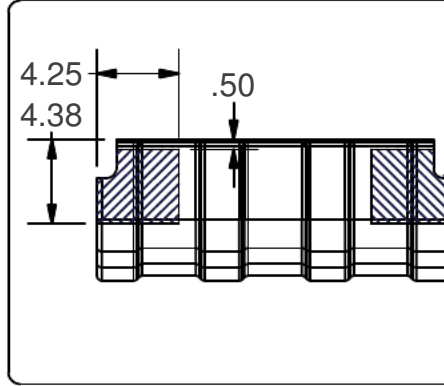

9. Bend heat shields back into original position. Hitch install is complete.

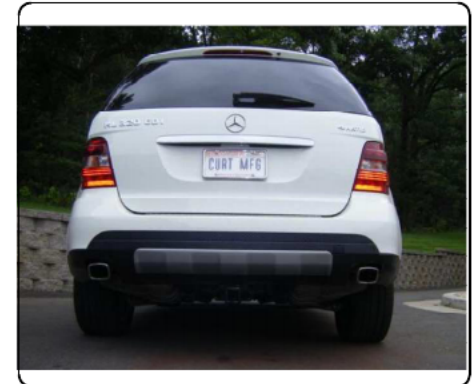

13342

2006-2010 MERCEDES-BENZ ML350 (EXCEPT BLUE TEC)
 2006-2007 MERCEDES-BENZ ML500
 2007-2008 MERCEDES-BENZ ML320 CDI
 2008-2009 MERCEDES-BENZ ML550

9/24/2012

WILL NOT FIT VEHICLES EQUIPPED WITH AIR SUSPENSION PAGE 1 of 2

GROSS LOAD CAPACITY WHEN USED AS A WEIGHT CARRYING HITCH: 3,500 LBS. TRAILER WEIGHT & 350 LBS. TONGUE WEIGHT.
 GROSS LOAD CAPACITY WHEN USED AS A WEIGHT DISTRIBUTION HITCH: 4,000 LBS. TRAILER WEIGHT & 400 LBS. TONGUE WEIGHT

DO NOT EXCEED VEHICLE MANUFACTURER'S RECOMMENDED TOWING CAPACITY.

HAVING INSTALLATION QUESTIONS? CALL TECHNICAL SUPPORT AT 1-877-287-8634

Parts List			
ITEM	QTY	PART NUMBER	DESCRIPTION
1	4	1/2-13 x 1 3/4	CARRIAGE BOLT
2	2	CM-SP4	.250 x 1.50 x 3.00" SQUARE HOLE SPACER
3	2	CM-SP6	.250 x 1.00 x 3.00" SQUARE HOLE SPACER
4	4	HFN 1213	HEX FLANGE NUT

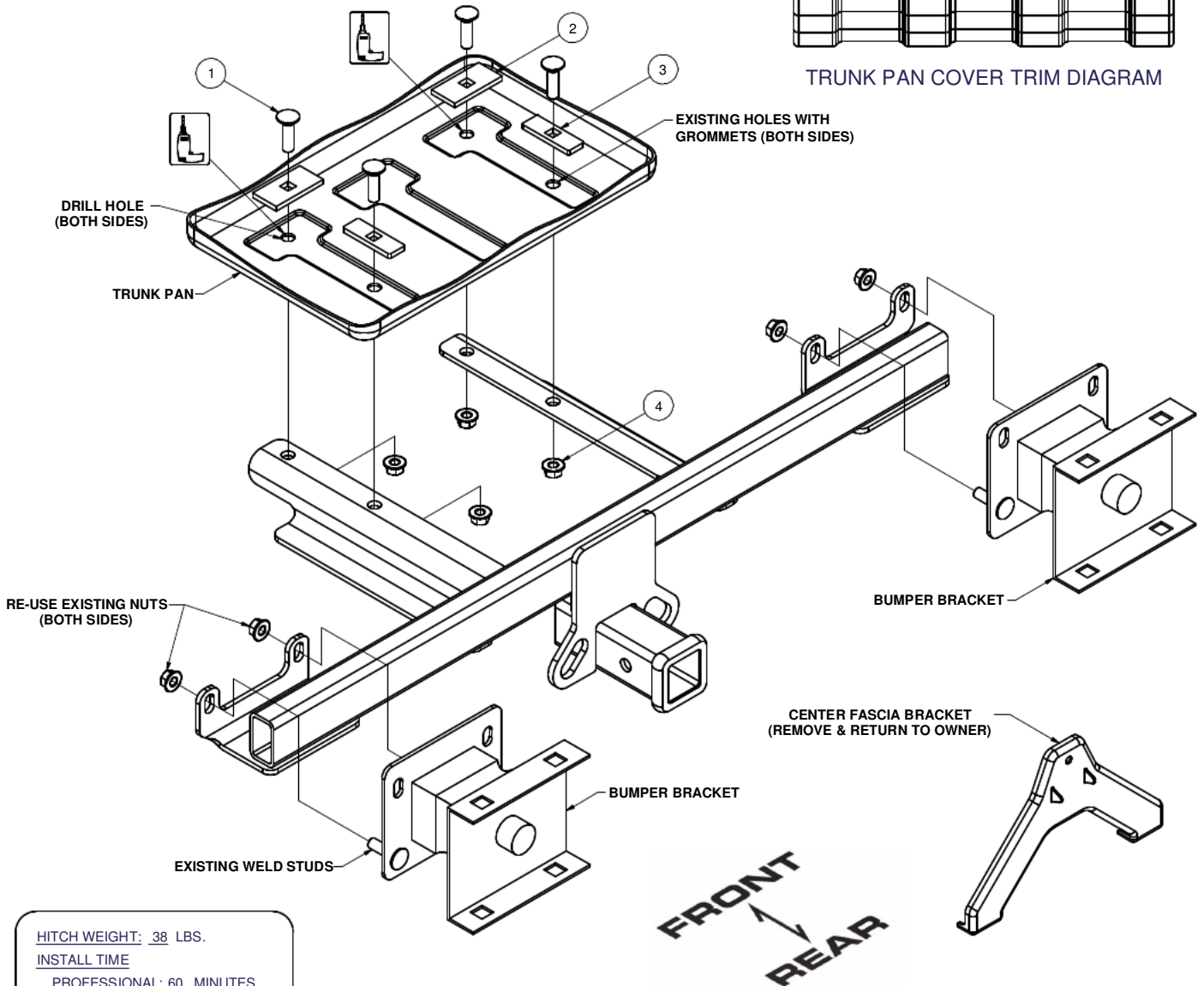
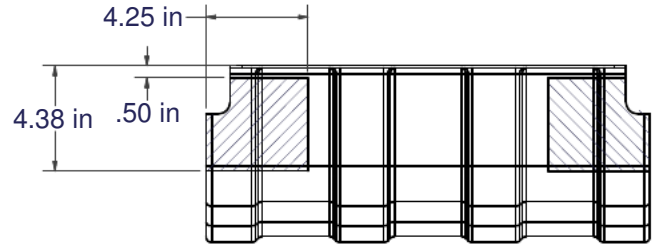

HITCH WEIGHT: 38 LBS.

INSTALL TIME

PROFESSIONAL: 60 MINUTES

NOVICE (DIY): 120 MINUTES

INSTALL NOTES:

- DRILLING REQUIRED
- FASCIA TRIMMING MAY BE REQUIRED

NOTE: LOWER FASCIA TRIMMING REQUIRED ON 2010 AND NEWER ML350 MODELS (SEE FASCIA TRIM DIAGRAM)

PERIODICALLY CHECK THIS RECEIVER HITCH TO ENSURE THAT ALL FASTENERS ARE TIGHT AND THAT ALL STRUCTURAL COMPONENTS ARE SOUND.

Curt Manufacturing Inc., warrants this product to be free of defects in material and/or workmanship at the time of retail purchase by the original purchaser. If the product is found to be defective, Curt Manufacturing Inc., may repair or replace the product, at their option, when the product is returned, prepaid, with proof of purchase. Alteration to, misuse of, or improper installation of this product voids the warranty. Curt Manufacturing Inc.'s liability is limited to repair or replacement of products found to be defective, and specifically excludes liability for incidental or consequential loss or damage.

13342

2006-2010 MERCEDES-BENZ ML350 (EXCEPT BLUE TEC)
2006-2007 MERCEDES-BENZ ML500
2007-2008 MERCEDES-BENZ ML320 CDI
2008-2009 MERCEDES-BENZ ML550

WILL NOT FIT VEHICLES EQUIPPED WITH AIR SUSPENSION PAGE 2 of 2

HAVING INSTALLATION QUESTIONS? CALL TECHNICAL SUPPORT AT 1-877-287-8634



PHOTO 1: TRIM FASCIA

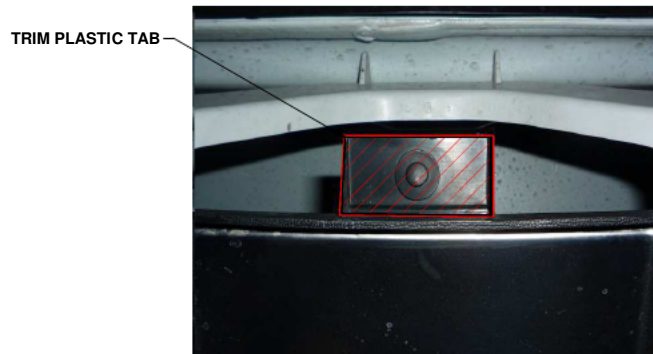
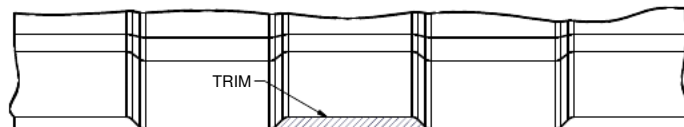
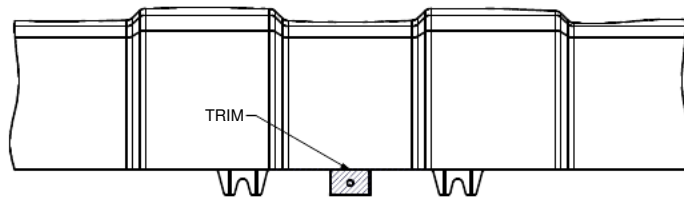

PHOTO 2: TRIM PLASTIC TAB



FASCIA TRIM DIAGRAM (REAR)



FASCIA TRIM DIAGRAM (BOTTOM)

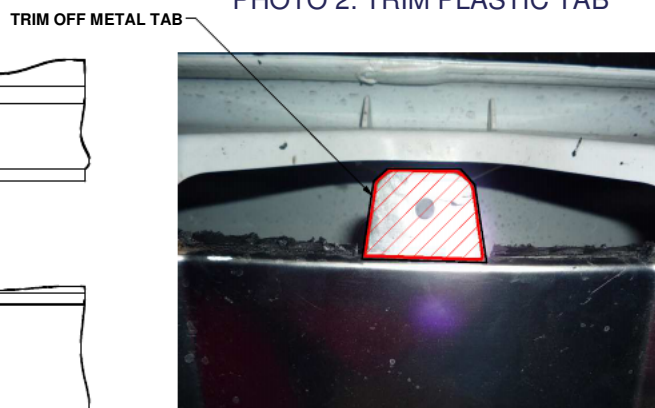

PHOTO 3: TRIM METAL TAB

INSTALLATION STEPS

Note:

- Will not fit vehicles equipped with air suspension.
- If installing on a ML350 2010 or newer; trim the center web of the lower rear fascia (Photo 1). Trim the center plastic fascia tab and the metal tab it is attached to (Photos 2 and 3). (See fascia trim diagrams)

Note: These install instructions are from a 2008 ML320 CDI. Your install may vary slightly.

1. Remove (4) fascia screws, retain (2) screws for later use. Remove the fastener securing the center fascia bracket and return bracket and bracket fasteners to owner.
2. Remove (4) nuts securing the trunk pan cover and remove cover. Note: Trunk pan cover may be trimmed and reinstalled if desired. (See Step (9) for trim details)
3. If needed bend back heat shields and remove (4) M10 nuts from the bumper bracket weld studs.
4. Raise hitch into position and secure to bumper bracket weld studs using (4) M10 nuts removed in Step (3). Re-install (2) fascia screws removed in Step (1). **Note:** Gently flex fascia and fascia brackets to slide hitch into position. You also may remove (2) fascia brackets if needed.
5. Open rear hatch, remove spare tire, foam tire locator, and pull carpet back. **Note:** When pulling carpet back push the carpet tab below the plastic trim and carefully fold it towards the front of the vehicle.
6. Remove (2) rubber hole plugs and return to owner. Using hitch as a template, drill the (2) forward-most holes in the trunk pan.
7. Install 1/2-13 x 1 3/4" carriage bolts and SP6 spacers in the rear-most holes of trunk pan. Install 1/2-13 x 1 3/4" carriage bolts and SP4 spacers in the forward-most drilled holes of trunk pan. Secure bolts using 1/2-13 flange nuts. Use silicone caulk or equivalent to seal holes in trunk. Re-install carpet, foam spare tire locator, and spare tire.
8. Torque all M10 fasteners to 48 ft-lbs. Torque all 1/2" fasteners to 110 ft-lbs.
9. If desired you may trim the trunk pan cover and re-attach using nuts removed in Step (2). (See trunk pan cover trim diagram)
10. Bend heat shields back into original position.

PERIODICALLY CHECK THIS RECEIVER HITCH TO ENSURE THAT ALL FASTENERS ARE TIGHT AND THAT ALL STRUCTURAL COMPONENTS ARE SOUND.

Curt Manufacturing Inc., warrants this product to be free of defects in material and/or workmanship at the time of retail purchase by the original purchaser. If the product is found to be defective, Curt Manufacturing Inc., may repair or replace the product, at their option, when the product is returned, prepaid, with proof of purchase. Alteration to, misuse of, or improper installation of this product voids the warranty. Curt Manufacturing Inc.'s liability is limited to repair or replacement of products found to be defective, and specifically excludes liability for incidental or consequential loss or damage.