

Preparation

**Part Number: PZQ44-42120**

**Kit Contents**

Item #	Quantity Req'd.	Description
1	1	LH Step Assembly
2	1	RH Step Assembly
3	1	LH Extrusion
4	1	RH Extrusion

**Hardware Bag Contents**

Item #	Quantity Req'd.	Description
5	12	Anchor bolt
6	12	Spacer Nut
7	12	M8 - Flat Washer
8	12	Plastic Clips
9	4	M6 U-Nut
10	4	M6x16x1.0 Bolt
11	12	M8x1.25 Hex Nut
12	1	Jack Warning Label

**Additional Items Required For Installation**

Item #	Quantity Req'd.	Description
1	1 (PT593-42000-LH)	Rocker Panel (trimmed) - LH
2	1 (PT593-42000-RH)	Rocker Panel (trimmed) - RH

**Conflicts**

None
------

**General Applicability**

MY19 and newer RAV4
---------------------

**Recommended Sequence of Application**

Item #	Accessory
1	
2	
3	

\*Mandatory

**Vehicle Service Parts** (may be required for reassembly)

Qty	Quantity Req'd.	Description
1	1	Rocker Panel - Left Hand
2	1	Rocker Panel - Right Hand
3	1	Step Assembly (Plastic step and Extrusion)
4	1	Plastic Step Assembly
5	1	Jacking Point Cover
6	1	Step Assembly (Plastic step and Extrusion)
7	1	Plastic Step Assembly
8	1	Jacking Point Cover
9	1	Side Step Fitting Kit (Per Side)
10	1	Jack Warning Label

**Recommended Tools**

<b>Personal &amp; Vehicle Protection</b>	<b>Notes</b>
Safety Glasses	
<b>Special Tools</b>	<b>Notes</b>
None	
<b>Installation Tools</b>	<b>Notes</b>
Trim Removal Tool	
Screwdriver	Phillips head
Ratchet	
Sockets	7mm, 10mm, 13mm & 1-5/16"
Extension	Short
Torque Wrench	0 to 60 N-m
Tape	Protective
<b>Special Chemicals</b>	<b>Notes</b>
None	

**Legend**

 **STOP:** Damage to the vehicle may occur. Do not proceed until process has been complied with.

 **OPERATOR SAFETY:** Use caution to avoid risk of injury.

 **CAUTION:** A process that must be carefully observed in order to reduce the risk of damage to the accessory/vehicle and to ensure a quality installation.

 **TOOLS & EQUIPMENT:** Used in Figures calls out the specific tools and equipment recommended for this process.

 **REVISION MARK:** This mark highlights a change in installation with respect to previous issue.

 **SAFETY TORQUE:** This mark indicates that torque is related to safety.

## **General Notes**

- Place these instructions in vehicle's glove box after installation is complete.
- Please read these instructions carefully before installation, paying special attention to all Notice & Caution notes.
- Failure to do so may result in damaged parts or injury to the installer or customer.
- It is recommended that this accessory is fitted only by a qualified Toyota technician.
- Ensure all recyclable discarded vehicle or accessory components and packaging are recycled following local recycling regulations.

## **General Vehicle and Accessory Warranty Notes and Cautions**

- Do not fit this Side Step to any other vehicle.
- Do not repair or modify the Side Step or its mounting hardware in any way - repair or modification can result in non-compliance with Regulatory Requirements and may effect proper operation of the airbag resulting in serious injury.
- Do not remove the label from the Side Step.
- Do not modify the vehicle in any way other than the manner specified in these fitting instructions. To do so may void the warranty.

## **General Vehicle Notes and Cautions**

- If damage or concerns are identified that may interfere with the installation of the accessory, or affect the function or safety of the vehicle, inform the customer prior to proceeding with the installation.
- Ensure special care is taken and the applicable repair manual is followed to prevent any damage to the vehicle.
- Protect and safely store any vehicle components removed.

## **General Accessory Notes and Cautions**

- It is advisable to seek assistance from another person when lifting heavy components
- This accessory is only to be fitted to the vehicles listed on the front of this manual, do not use this product for any make or model not listed as it may render the vehicle unsafe to operate.
- Fit the accessory only using the method outlined in these instructions, do not fit the accessory by any other method or attachment points.

## **Side Step Care Procedures**

- Daily Exposure to pollution in the air, road grime and corrosive environments such as sea side roads can affect the appearance and finish of the accessory.
- Regularly wash the accessory using a reputable automotive wash detergent, rinse with fresh water and chamois dry.

## **WARNING!**

- Do Not Use Harsh Chemicals, industrial Cleaners or solvents.
- Do Not use abrasive compounds or abrasive cleaning tools
- Use reputable cleaning products only, as recommended by the manufacturer.

## — Parts Supplied —

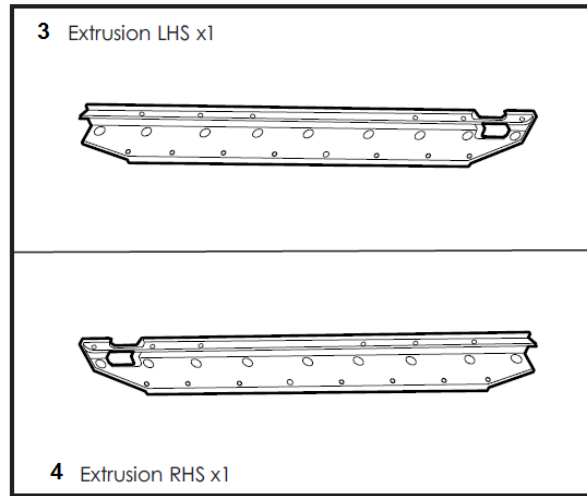
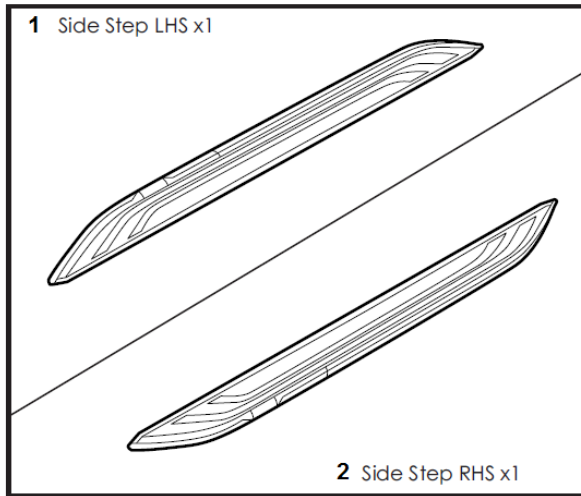

### Hardware Kit

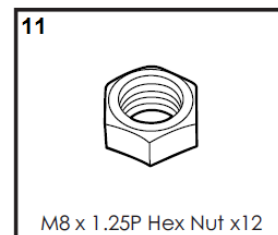
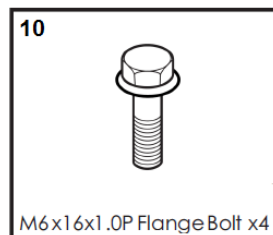
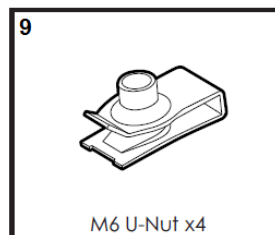
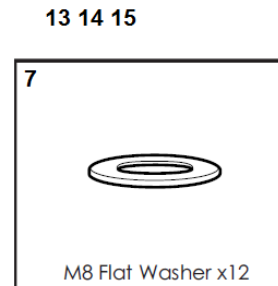
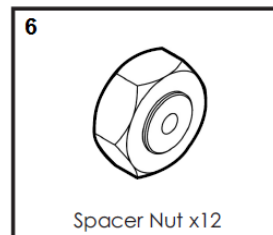
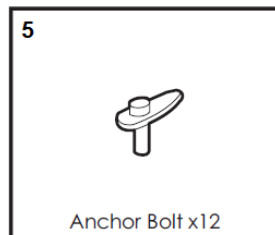

Exploded View

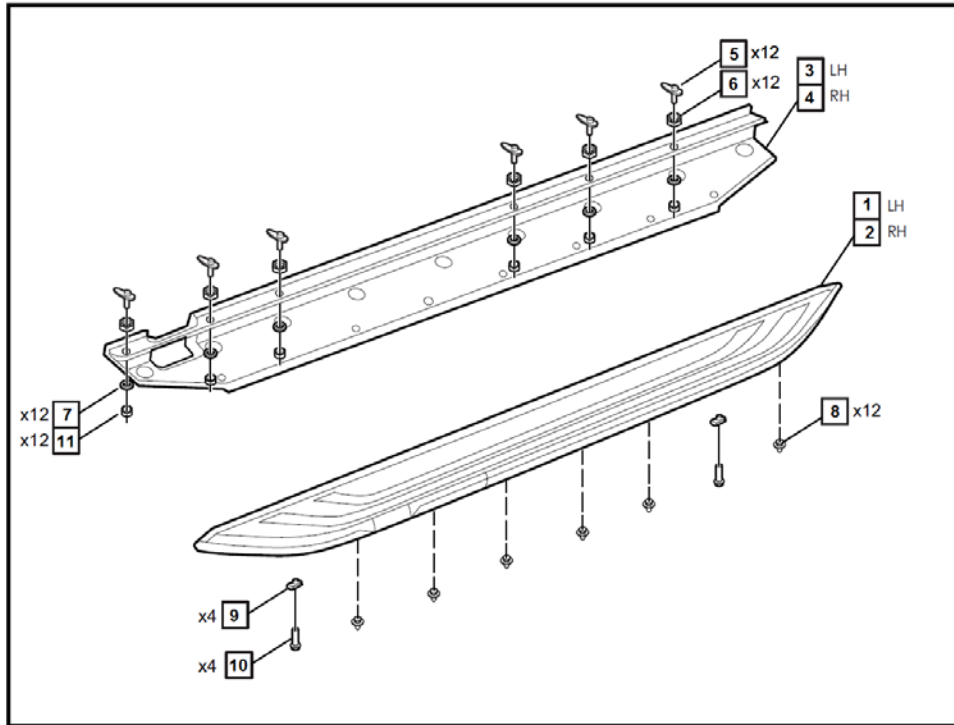

Care must be taken when installing this accessory to ensure damage does not occur to the vehicle. The installation of this accessory should follow approved guidelines to ensure a quality installation.

These guidelines can be found in the "Accessory Installation Practices" document.

This document covers such items as:

- Vehicle Protection (use of covers and blankets, cleaning chemicals, etc.).
- Safety (eye protection, rechecking torque procedure, etc.).
- Vehicle Disassembly/Reassembly (panel removal, part storage, etc.).
- Electrical Component Disassembly/Reassembly (battery disconnection, connector removal, etc.).

Please see your Toyota dealer for a copy of this document.

**1. Prepare the Vehicle.**

- (a) Remove all parts from the carton and discard packaging.
- (b) Verify that all parts are present.



**2. Install the Passenger's Side Running Board.**

- ⚠ (a) Apply protective tape to the RH rear wheel arch trim, and the rocker molding area (Fig. 2-1).

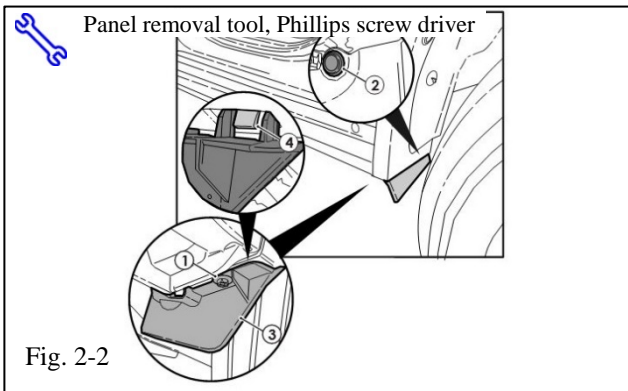

- (b) Release the wind deflector.

- (1) Remove and retain bolt (1) and push pin (2) from the rear wind deflector (3) (Fig. 2-2).
- (2) Release the clip (4) to allow the deflector to hang loosely.



- (c) Release the front mudguard (if present).

- (1) Remove the bottom push pin and retain (Fig. 2-3).

⚠ **NOTE:** Do NOT remove the top pin.

- (2) Remove the (2) screws from the RH front mud guard and retain.



(3) Leave the top push pin and move mudguard out of the way (Fig. 2-4).

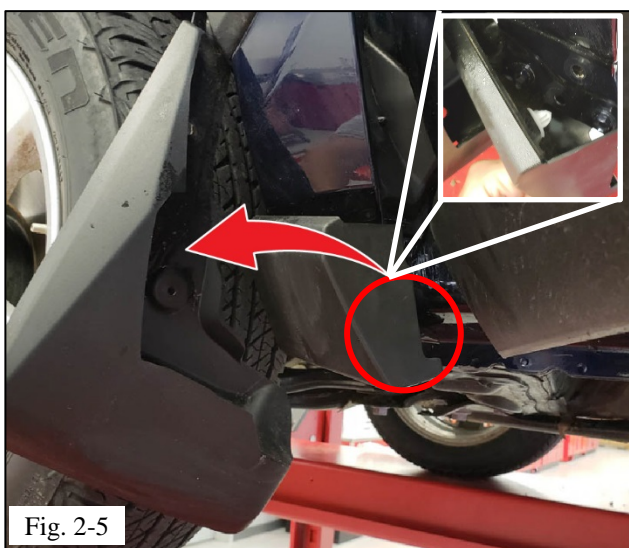

(d) Disengage front trim (Fig. 2-5).

(1) Pull outwards to disengage the white pin.



(e) Remove and retain the 8-plugs (Fig. 2-6).

**⚠ NOTE:** Careful not to damage as (6) of them will be reinstalled.



(f) Remove and retain the front 2-Push pins (Fig. 2-7).

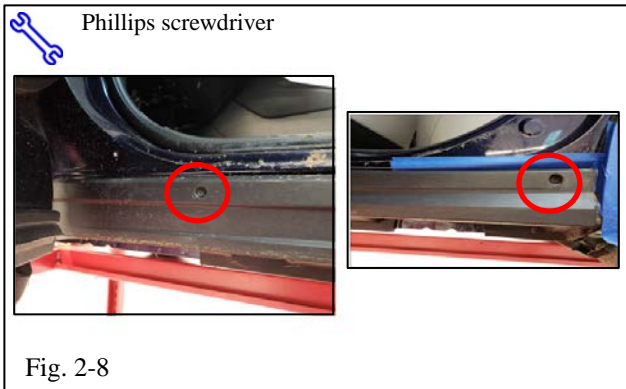

(g) Remove and retain the 2 screws from the rocker molding (Fig. 2-8).



- (h) Pull the rocker molding outboard to release the 9-plastic clips inside the panel (Fig. 2-9).
- (i) Push the sill molding towards the front of the vehicle to release from the rear wheel arch molding, then pull the sill molding rearward and clear of the vehicle.

**STOP** NOTE: Do not pull on the rear fender. Pulling on the fender trim may damage the double-sided tape.



- (j) Install a spacer nut onto each anchor bolt, until the end of the bolt is approximately flush with the bottom of the spacer nut (Fig. 2-10).

**⚠ NOTE:** Ensure the correct spacer nut orientation (emboss towards anchor plate).



- (k) Install (6) anchor bolts into sill section of the vehicle with the longer tab towards the rear (Fig. 2-11).

**⚠ NOTE:** Do not fully tighten the anchor bolts at this time.



- (a) Ensure that the anchor bolts are installed into the (6) locations (Fig. 2-12).

**⚠ NOTE:** The (2) middle locations are NOT applicable.

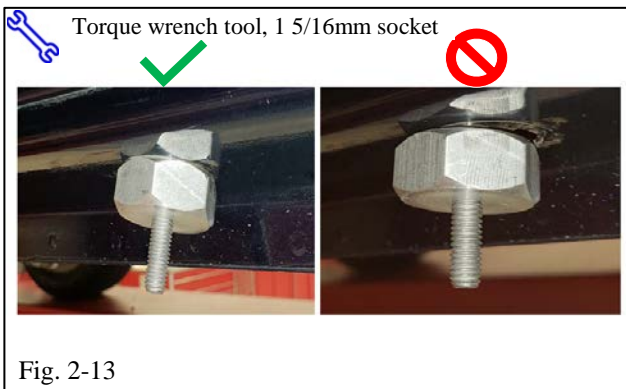

- (b) Ensure that the spacer nut boss is flush against the surface (Fig. 2-13).

- (c) Torque the spacer nuts to 45 N-m

**Torque: 45 N-m (33 ft-lb)**





Fig. 2-14

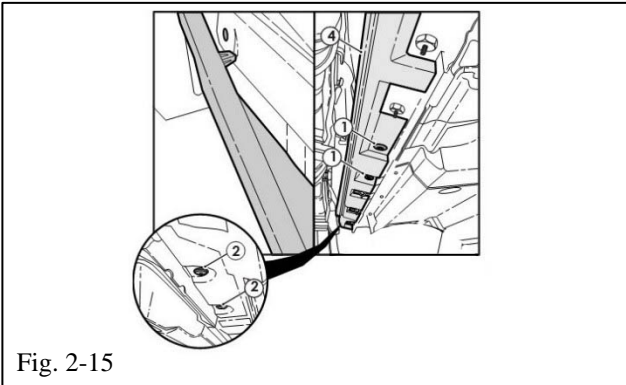

Fig. 2-15

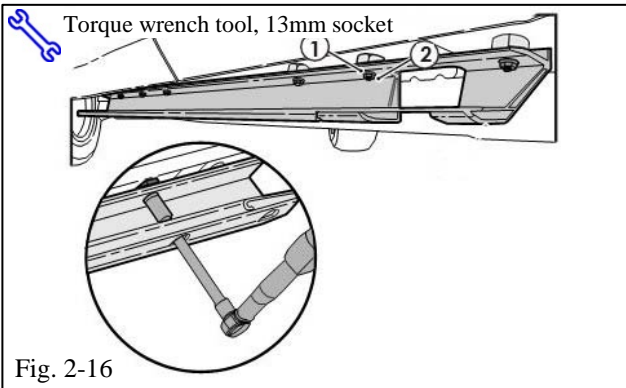

Fig. 2-16

- (d) Retrieve the new rocker molding panel with cutouts (Fig. 2-14)
  - PT593-42000-RH
- (e) Install to the vehicle in reverse order as the original rocker was pulled, slide in the back before inserting the clips.
- (f) The protective tape can now be removed.
- (g) Reinstall with (2) of the previously removed plugs (1), 2 push pins (2), and 2 screws (4) (Fig. 2-15).
- (h) Discard the remaining plugs.
- (i) Reinstall the rear wheel wind deflector with (1) scrivet and (1) bolt.
- (j) Remove protective tape.
- (k) Install the RH extrusion to the vehicle.
- (l) Install 6-flat M8 washers and hex nuts (1) & (2) to anchor bolts (Fig. 2-16).
- (m) Hand-tighten to a snug condition.
- (n) Torque all hex nuts to 24 N-m  
**Torque: 24 N-m (18 ft-lb)**

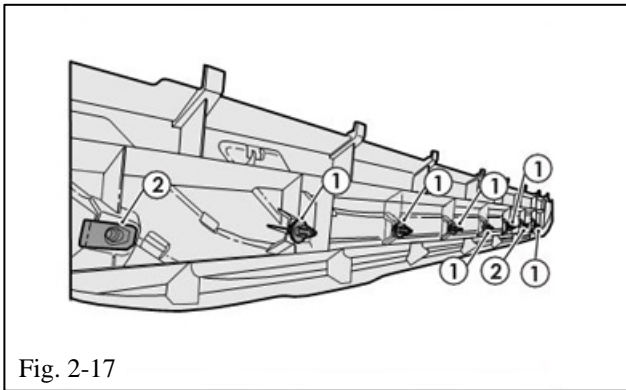

Fig. 2-17

- (o) Install 6-plastic clips (1) and 2-U-nuts (2) into the plastic step (Fig. 2-17).

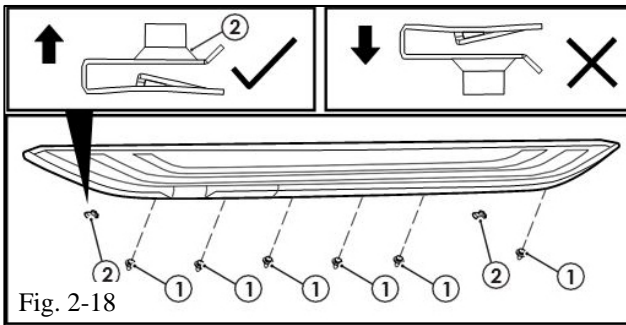

Fig. 2-18

**⚠ NOTE:** Ensure correct U-nut orientation (Fig. 2-18).

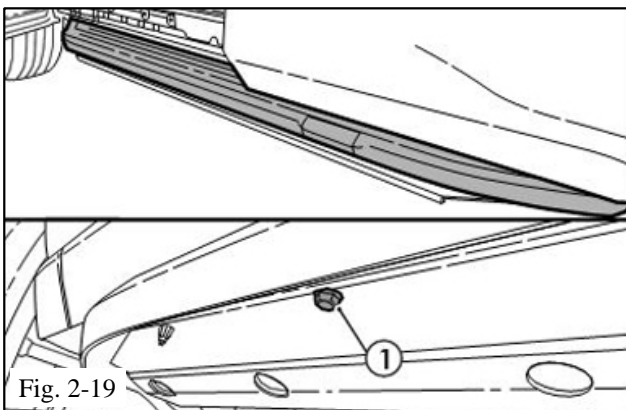

Fig. 2-19

- (p) Ensure the front door is open, and rear door is closed (Fig. 2-19).



Fig. 2-20

- (q) Align the step hooks with the aluminum extrusion holes (Fig. 2-20).
- (r) Install the hooks on the plastic step into the large holes in extrusion.
- (s) Align clips and press down on the plastic step until clips lock in place.

**⚠ NOTE:** Make sure all pins engaged.

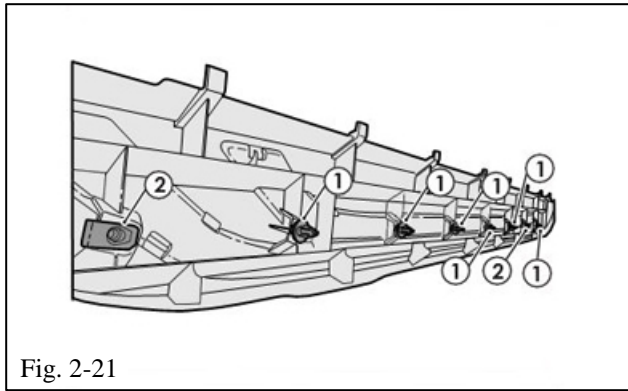

Fig. 2-21

- (t) Install a flange bolt into each U-nut and torque to 6 N-m (5 ft-lb) (Fig. 2-21).

**Torque: 6 N-m (5 ft-lb)**

### 3. Reinstall the Front Trim

- (a) Align the white clip and push.
- (b) Reinstall the mudguard (if needed).
- (c) Remove protective tape from the vehicle and reinstall the front mudguard with original fasteners.
- (d) Repeat Steps 2(a) – 2(t) for the left-hand side.

### 4. Attach the Jack Warning Label

- (a) Attach the Jack warning label (Item L) to the vehicle jack (Fig. 4-1).

**STOP NOTE:** Ensure the existing label on the jack is NOT covered by the new jack warning label.

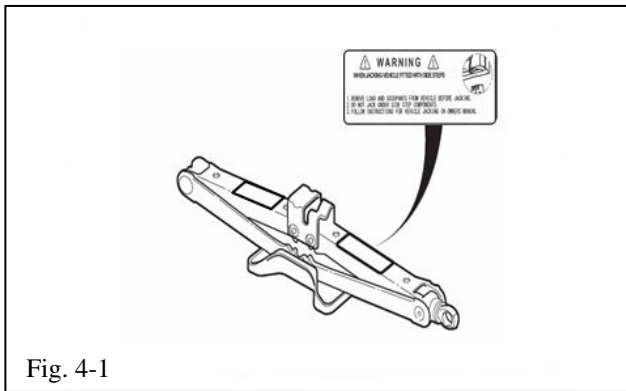

Fig. 4-1



Fig. 4-2

- (b) Remove the protective film from steel inserts on each side step (Fig. 4-2).

**TOYOTA RAV4/RAV4 HV 2019 - RUNNING BOARDS**

Checklist - these points **MUST** be checked to ensure a quality installation.

<u>Check:</u>	<u>Look For:</u>
<p><u>Accessory Function Checks</u></p> <ul style="list-style-type: none"><li><input type="checkbox"/> Step alignment</li><li><input type="checkbox"/> Uniform gap between Step and Rocker panel</li><li><input type="checkbox"/></li><li><input type="checkbox"/></li></ul>	<ul style="list-style-type: none"><li><input type="checkbox"/> Running board must be centered to vehicle.</li><li><input type="checkbox"/> Visually inspect.</li></ul>
<p><u>Vehicle Function Checks</u></p> <ul style="list-style-type: none"><li><input type="checkbox"/></li><li><input type="checkbox"/></li></ul>	
<p><u>Vehicle Appearance Check</u></p> <ul style="list-style-type: none"><li><input type="checkbox"/> After accessory installation and removal of protective cover(s), perform a visual inspection.</li></ul>	<p>Ensure no damage (including scuffs and scratches) was caused during the installation process. (For PPO installations, refer to TMS Accessory Quality Shipping Standard.)</p>